

## Fingerprint Imaging 2022

# ForensiScan

Automated Photography and Enhancement  
of Fingerprints on Cylindrical, Curved and/or  
Highly Reflecting Evidence

ForensiScan –  
easy to use, fast, economical

## Forensic Fingerprint Imaging

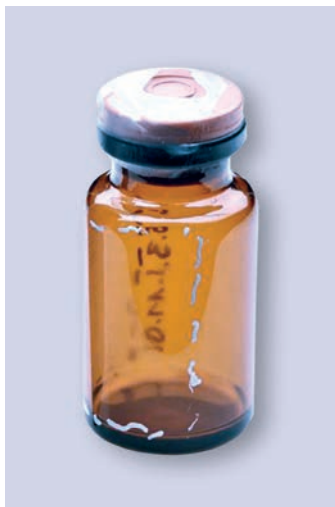

The photographic documentation of visible or chemically enhanced fingerprints on the surface of cylindrical, curved or reflective evidence is associated with a number of difficulties and therefore often involves a considerable effort.

Cylindrical evidence, such as bullet casings, drinking glasses, bottles, ampoules, cans, etc., pose a particular challenge as the depth of field in a photographic image decreases with increasing magnification. Therefore, the conversion of a curved surface into a two-dimensional "photographic" image inevitably results in a geometrically incorrect photo.

With conventional photographic methods, such fingerprint or trace images can only be recorded in several sections and with geometric errors. The analysis and comparison of individual characteristic in several images is therefore not an optimal basis for the subsequent dactyloscopic evaluation of a fingerprint.

Finger or grip marks that extend over a larger section on the outside of a cylinder can naturally not be visualised when viewed frontally because a part of the handprint on a circular surface facing away from the observer is hidden by the evidence item itself.

## ForensiScan – Photographic Fingerprint Scanner

**CLAUSS**

ForensiScan was specially developed for capturing fingerprints and other forensic traces on "complex" surfaces. Special attention was paid to the photographic documentation of fingerprints on cylindrical objects such as glasses, bottles, cartridge casings and on exhibits with highly reflective surfaces such as chip cards, mirrors or CDs.

To capture fingerprints on the surface of cylindrical items geometrically correct, the outside of such objects is scanned with high precision in a linear mode. The required accuracy of the scanning process is achieved by a precisely controlled stepper motor driven rotation of the object under examination in the focal plane of the ForensiScan's camera. The system's software automatically compiles the linear images into a geometrically exact duplicate of the cylinder outside.

In addition to cylindrical objects, the ForensiScan can also be used to examine planar surfaces. For this purpose, the object to be examined is moved along the camera's plane of focus by means of a special linear slide unit. This method is particularly suitable for capturing fingerprints on highly reflective or transparent objects such as credit cards, CDs, stainless steel blades, etc.

The precise positioning of the object in front of the system's camera, as well as the fully automated scanning process, are ensuring an efficient workflow with excellent photographic results in high resolution.

## ForensiScan – Structure and major System Components

A high resolution camera module and an evidence area are sitting opposite each other on a torsion-resistant base frame. The evidence area can be equipped with either a turntable, a jaw chuck device or a linear slide

unit. The camera unit is mounted on a movable slide and equipped with several precision-mechanical gear units. With the help of the gear units, the camera can be tilted or rotated and moved in all three dimensions.

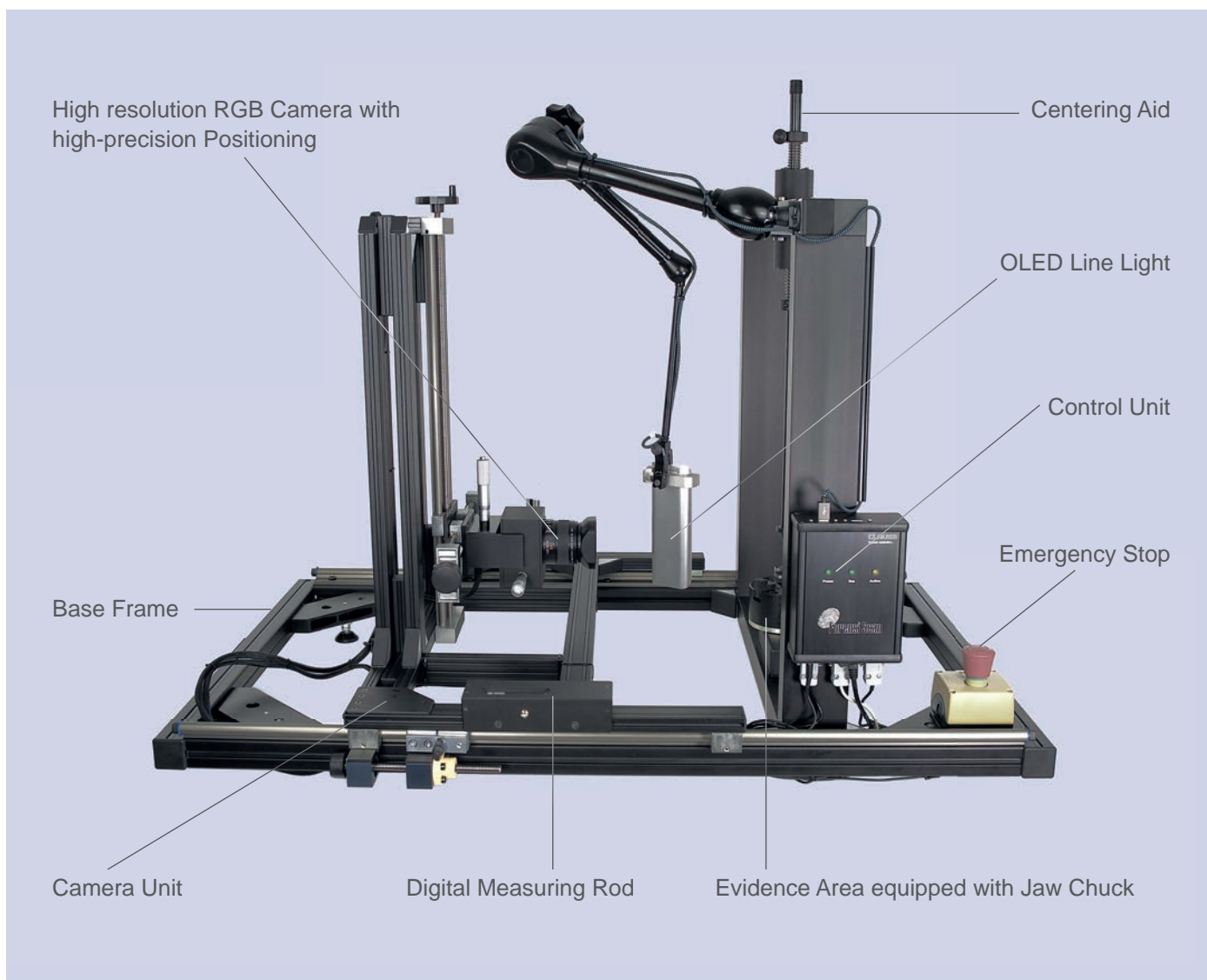

A special OLED line light with a natural colour spectrum is available for illuminating the capturing area on the surface of the evidence. The possibility to illuminate the surface of an object in a linear form in compliance with the recording method opens up completely new areas of application for forensic fingerprint photography.

Interfering reflections, shadows or poorly illuminated areas on the surface of cylindrical or transparent evidence items are effectively eliminated by the linear scanning mode in combination with a “line-shaped” illumination.

On the other hand, by capturing an image directly in the reflective plane or directly besides an illuminated column, it is possible to photograph fingerprints on mirrors and other highly reflective surfaces without generating disruptive double reflections.

Independently of the built-in line light, the open design of the ForensiScan allows the application of various other types of lamps, e.g. special forensic light sources. These other light sources can be flexibly positioned around the evidence area and applied for optimal illumination of the evidence under examination.

## ForensiScan – User Interface

A dedicated software package controls the rotation of the object under examination and the capturing process of the ForensiScan camera unit. The camera is completely actuated digitally and all camera parameters (focus, aperture, resolution, gain) are set directly in the user interface.

While the capturing parameters are set or during the recording process, the events in front of the camera can be followed live on the screen.

The final resolution, as well as the size of the fingerprint image, are continuously displayed on the user interface and can be adjusted accordingly if necessary.

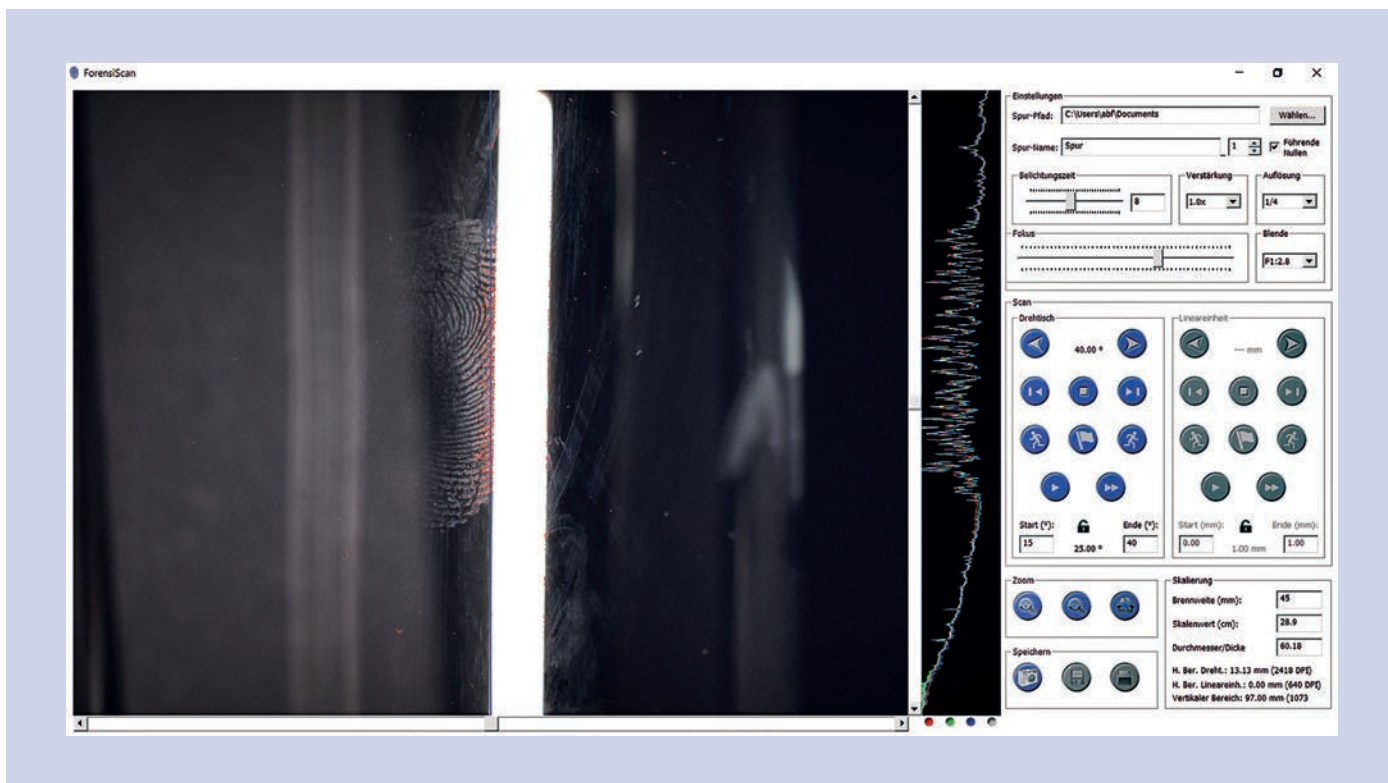

## The Capturing Process

### 1 Position your exhibit

The exhibit to be examined is placed in the centre of the evidence area and precisely aligned with a special centring tool.

### 2 Selecting image section and setting the illumination

With support of the user software and it's live preview mode, the desired image section is selected and the illumination is set to the required position and intensity.

### 3 Adjusting focus and camera parameters

The image is brought into focus using the digital autofocus function. The software also allows to set the optimal photographic conditions for exposure time, gain and resolution.

The final resolution of the image is displayed on the user interface and can be adjusted as needed.

### 4 Starting the recording process

After all the settings have been made, the capturing process is started. The process is fully automatic. The object is set into a rotary or linear movement and scanned at the correct angle or in the correct direction.

After the scanning process is completed, a high resolution image of the finger- or handprint is immediately available. The forensic image is automatically displayed with a comparison scale. Objects with identical dimensions can be scanned with identical parameters in a "batch" processing mode.

## System Components and Accessories

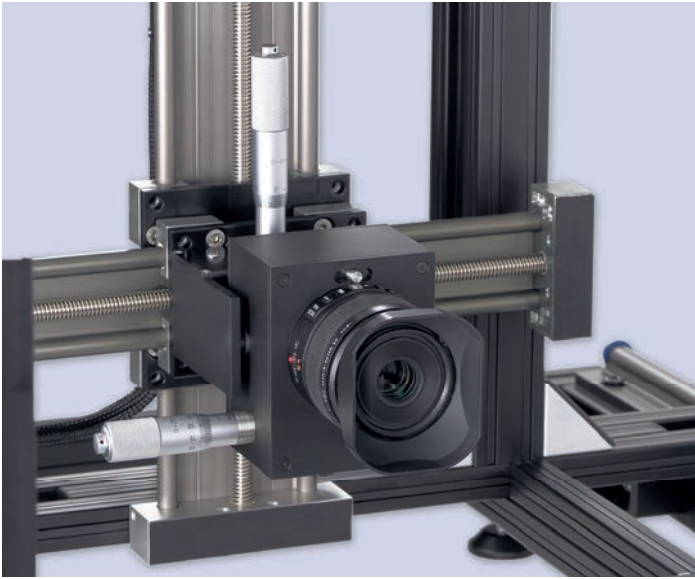

The ForensiScan is equipped with a high resolution RGB camera and a motorised lens.

All camera parameters (focus, aperture, resolution, gain) are set digitally via the user software. To simplify focus adjustment, the software has an integrated autofocus function and the option of “focus peaking”.

The position of the camera in relation to the evidence object can be precisely adjusted with the help of fine mechanical gears. Roll angle and tilt of the camera can be adjusted with micrometer screws.

Optionally, the camera can be supplied with an extended spectral range for images in the near infrared range (up to 950 nm).

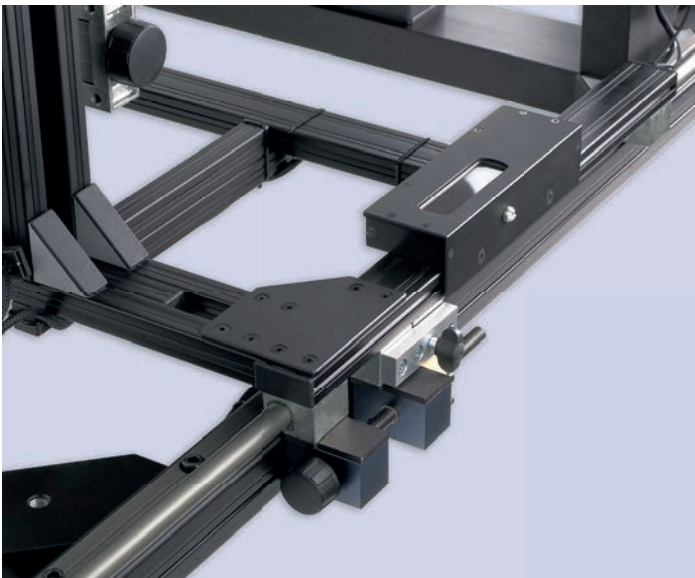

For correctly capturing images of the outer side of a cylindrical item, two size parameters (object diameter (or object thickness) and distance of the object from the camera) must be transmitted to the software.

To determine the object diameter, an electronic caliper is available whose measurement values are automatically transferred into the user software. The object distance is also determined automatically via a built-in glass measuring rod.

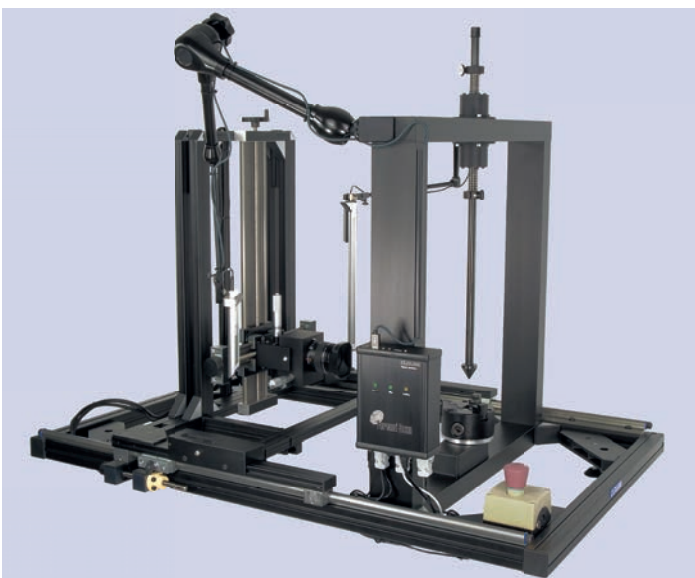

To protect evidence items under examination against contamination with traces of foreign DNA, the object area is covered with plain black aluminium profiles. In addition, an easy-to-clean plastic cover is available to protect the turntable surface and a silicone cover for the jaw chuck.

## System Components and Accessories

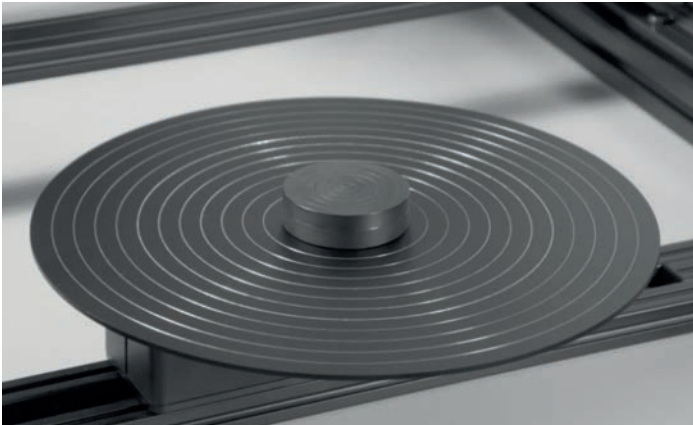

For positioning cylindrical objects, a turntable with engraved circles is available as a centring aid.

Small objects are positioned with an additional disc (“puck”) with likewise concentric circles, which is placed centrally.

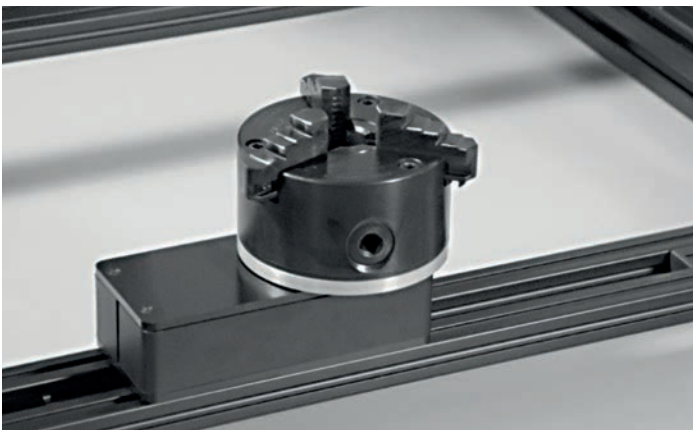

For objects that do not have a stable base, a triple jaw chuck can be used for positioning purposes.



The ForensiScan is equipped by default with an OLED line light with particularly homogeneous light intensity distribution. Due to the line-shaped illumination pattern, disturbing reflections, shadows or even interfering elements of the exhibit can be effectively faded out.

The line light has a natural wave length spectrum and is mounted directly to the exhibit frame of the ForensiScan with a flexible holding arm.



A linear slide unit is available for scanning planar exhibits, such as credit cards, mirrors, CDs, etc.

## ForensiScan – Application Examples

### Example 1: Ampoule

The evidence shown in the image on the left is a brown glass ampoule with a diameter of 2.2 cm. The glass surface was diffusely illuminated with white light. The inner walls and the rear parts of the cylindrical ampoules which usually would appear in a two dimensional photo captured under standard light conditions are hidden by this specific mode of illumination.

(Source: Bavarian State Criminal Police Office)

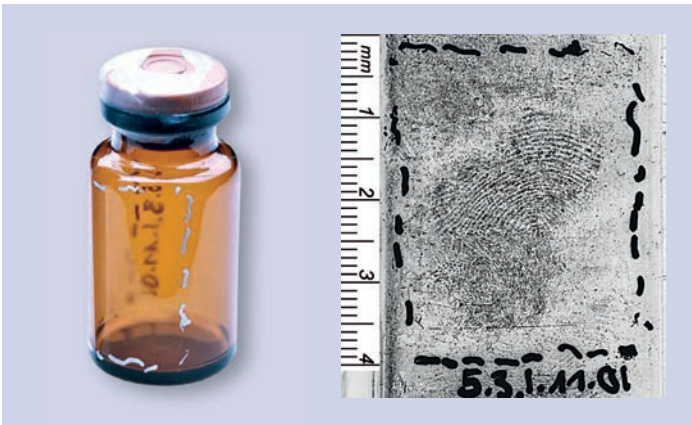

### Example 2: Cartridge case

The metallic surface structure of cartridge cases produces reflections/light drops on the case body when trying to illuminate the outer surface. In addition, such objects frequently show damages in the form of scratches, slight deformations or areas with oxidations. By scanning the surface “line by line” unfavourable characteristics will be significantly suppressed.

(Source: Bavarian State Criminal Police Office)



### Example 3: Lamp

The adjacent image shows a high-pressure metal vapour lamp with a ceramic base and an untreated fingerprint on the glass surface. With conventional photographic methods, parts of the lamp interior would appear in the photo. By using a “line by line” capturing mode the internal elements of the lamp are effectively masked out.

Only a stabiliser, which is in direct contact with the inner side of the glass body, is appearing in the image and is shown as a “black line”.

(Source: Bavarian State Criminal Police Office)



### Example 4: Plastic bottle

In the image on the left a handprint on the outer surface of a PET bottle is shown. The handprint was chemically enhanced by cyanoacrylate. The exhibit was illuminated with the ForensiScan line light.

(Source: State Criminal Police Office Baden-Württemberg)



## ForensiScan – Technical Specifications

### Dimensions

110 cm x 78 cm x 80 cm

### Weight

approx. 20 kg

### Maximum resolution (vertical x horizontal)

Rotary mode: 4,096 x 72,000 Px (294 MPx)

Linear mode: 4,096 x 80,000 Px (326 MPx)

### Camera and lens

RGB camera

Resolution: 4096 x 3000 px RGB

F = 45 mm

Lens mount: MFT interchangeable lens

Max. distance to rotation axis: 0 mm - 500 mm

Max. height above turntable: 450 mm

Vertical angle of view: 15.8° (roll angle adjustable)

### Turntable

Internal reference angle

Maximum object size: 500 mm x 500 mm

Angular resolution: 0.005°

Load capacity: 20 kg

### Turntable

Surface: aluminium, black

Diameter: 300 mm

With concentric centring circles

Black plastic disc for height adjustment ("Puck")

### Clamping device

Designed as triple jaw chuck

Colour: black

Object diameter 0 mm - 120 mm Optional

Additional positioning aids on request

### Centring aid

universal centring tip with different design options

Height adjustable

Contact pressure variably adjustable

### Linear unit

Internal reference position

Quick-change adapter

Linear resolution: 0.005 mm

Maximum distance: 40 cm

**abf** diagnostics GmbH

### abf diagnostics GmbH

Gewerbepark 14

D-85402 Kranzberg

Germany

T +49 8166 9986 130

F +49 8166 9986 140

E [info@abfdiagnostics.com](mailto:info@abfdiagnostics.com)

[www.abfdiagnostics.com](http://www.abfdiagnostics.com)